

REVISION			
REV.	DESCRIPTION	DATE	APPROVED
A	Changed P1 Pin Out / Changed Cable Spec From 30AWG To 28 AWG	03-12-07	DP

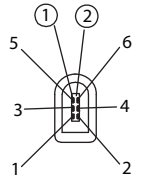

FRONT

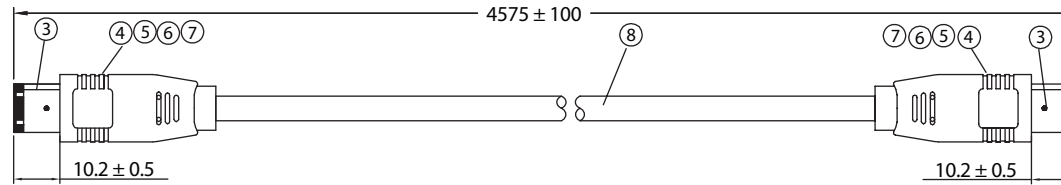

IEEE 1394 6P/M MOLDING TYPE  
(TOOLING NO:G102-216)

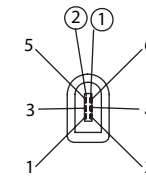

FRONT

P2

IEEE 1394 6P/M MOLDING TYPE  
(TOOLING NO:G102-216)

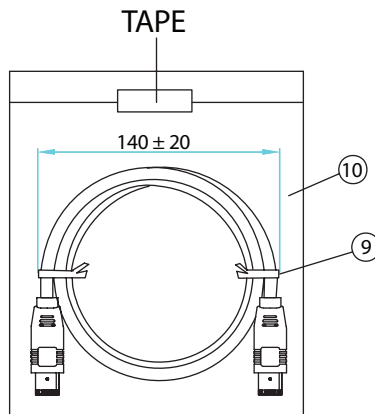

TAPE

PIN OUT

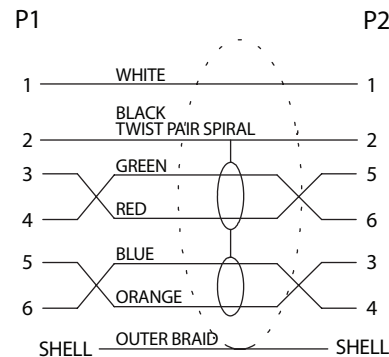

NOTES:

- CABLE: UL20276 IEEE1394  
[(28AWGx1P+FOIL+SP)x2+22AWGx2C+MYLAR+FOIL+BD]x1  
OUTER PVC JACKET: BLACK, OD: 6.2 ± 0.2mm  
PRINTING: "E166307  AWM 20276 28AWG VW-1 IEEE Std 1394 Compliant"
- CONNECTORS: IEEE 1394 6P MALE TO IEEE 1394 6P MALE
- HOOD: MOLDED TYPE, COLOR: BLACK
- ELECTRICAL TEST:  
<1>.100% OPEN SHORT & MISS WIRE TEST  
<2>.INSULATION RESISTANCE: DC400V 10M ohm MIN.  
<3>.CONDUCTOR RESISTANCE: 1 ohm MAX.
- PACKING: 1PC/POLYBAG

No.	PARTS NAME	SPECIFICATION STANDARD	QTY	REMARKS
①	6P/M - CONTACT	PHOSPHOR BRONZE / GOLD FLASH	12	
②	6P/M - INSULATOR	PBT / BLACK UL94V-0	2	
③	6P/M - SHELL 1	SHELL / NICKEL PLATED	2	
④	6P/M - SHELL 2	SHELL / NICKEL PLATED	2	
⑤	COPPER FOIL	5x10mm	2	
⑥	6P/M - INNER MOLD	PE / NATURAL	2	
⑦	6P/M - OUTER MOLD	45P PVC / COLOR: BLACK	2	
⑧	KL02003ABK01A	[(28AWGx1P+FOIL+SP)x2C+22AWGx2C+MYLAR+FOIL+BD]x1 COLOR: BLACK	1	
⑨	MINI TIE	PE / BLACK	2	
⑩	POLYBAG	PE / 0.08x180x200mm	1	

Dim range (mm)	Tolerance +/- (mm)	Qualtek Electronics Corp. WCI DIVISION					
		Part Number: 1821019-15					
0-1	0.15	Description: IEEE 1394 6P/M - IEEE 6P/M					
1-6	0.20	REV. A					
6-18	0.30						
18-50	0.50						
50-120	0.70				Drawn / Date	Checked / Date	Approved / Date
120-250	0.90				B. Grubb 01-25-07	01-25-07	JJH / 01-25-07
250-500	1.20						